



**ELIZADE UNIVERSITY**  
**ILARA-MOKIN**  
**ONDO STATE**

**FACULTY:** Basic and Applied Sciences  
**DEPARTMENT:** Physical and Chemical Sciences  
**FIRST SEMESTER EXAMINATIONS**  
**2016/2017 ACADEMIC SESSION**

**COURSE CODE:** PHY 311

**COURSE TITLE:** ELECTRIC CIRCUIT THEORY II

**DURATION:** 2 HOURS

A rectangular box containing a handwritten signature in black ink.

**HOD's SIGNATURE**

**TOTAL MARKS:**

**Matriculation Number:** \_\_\_\_\_

**INSTRUCTIONS:**

1. Write your matriculation number in the space provided above and also on the cover page of the exam booklet.
2. This question paper consists of 2 pages with printing on both sides.
3. Answer all questions in the exam booklet provided.
4. More marks are awarded for problem solving method used to solving problems than for the final numerical answer.
5. Box your final answers.
6. Attempt any 4 of the 6 questions

Q1.(a) Describe two-port network with 3 examples.

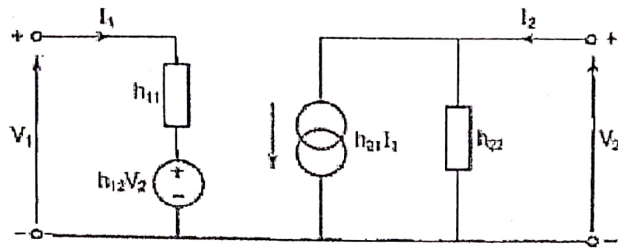

Figure I.

(b). A transistor has the following h-parameters:  $h_{11} = 1 \text{ k}\Omega$ ;  $h_{12} = 10^{-3}$ ;  $h_{21} = 100$ ;  $h_{22} = 10^{-4} \text{ S}$ . Using the equivalent circuit of Figure I above determine (i) the voltage gain ( $V_2/V_1$ ) and (ii) the current gain ( $I_2/I_1$ ) when a load resistance of  $1 \text{ k}\Omega$  is connected across the output terminals.

Q2.(a). Define the following (i) Node (ii) Open Circuit (iii) Mesh

(b). Three  $20 \text{ }\Omega$  resistors are connected in star and a voltage of  $480 \text{ V}$  is applied across two of them. If three other resistors (identical to each other) are connected in delta and the same supply is connected across one of them, determine the

(i) value of the delta connected resistors.

(ii) current in each of the delta connected resistors. The supply current is the same as before.

Q3. (a) State the Kirchhoff's current law

(b) Three resistors having resistances of  $100\Omega$ ,  $200\Omega$  and  $1\Omega$  are connected in delta. Show the connection of the resistors and determine the resistances of the equivalent star connected resistors.

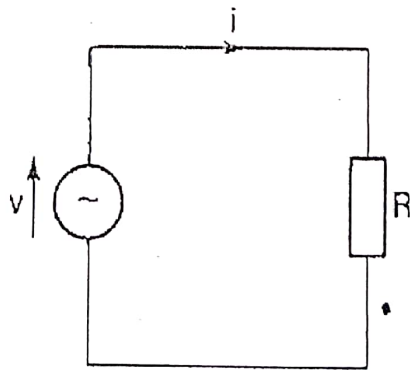

Fig II.

Q4. (a) In the circuit of Fig. II,  $R = 10 \text{ }\Omega$  and  $v = 35 \sin 214t$ . Determine (i) the rms value of the current, (ii) the phase angle of the circuit, (iii) the frequency of the supply.

- (b) In the circuit of Fig. II, replacing the resistor with inductor  $L$  with  $L = 5 \text{ mH}$ ,  $i = 20 \sin 25\pi ft$  and  $f = 400 \text{ Hz}$ . Calculate (i) the inductive reactance of the circuit, (ii) the rms value of the supply voltage.

- Q5.a.(i) State the advantages and disadvantages of R-2R ladder network.  
(ii) Mention the uses of R-2R ladder network

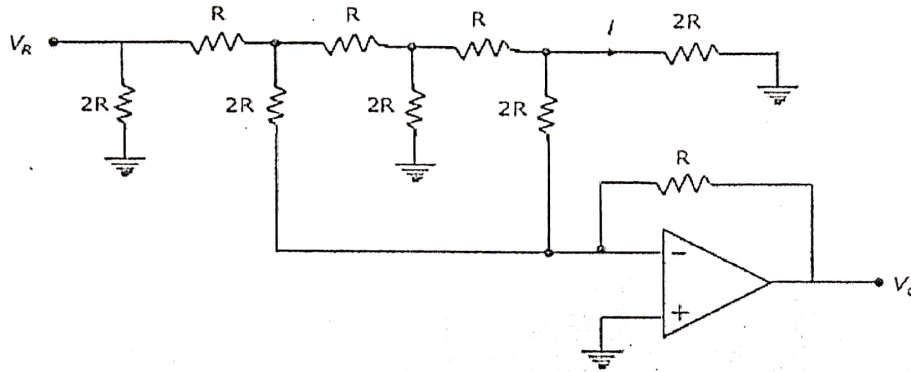

Fig. III

- (b). In the Digital-to-Analog converter circuit shown in the figure III above, if the reference voltage  $V_R$  is given to be  $15\text{V}$  with the resistance value  $R$  to be  $10 \text{ k}\Omega$ . Determine the

- (i) Current  $i$   
(ii) Voltage output  $V_o$ .  
(iii) New Voltage output  $V_o$  if a digital signal of 1011 is applied to it.

- Q6.a (i) State the three symmetrical balanced phasors to which any set of unbalanced voltages or currents can be resolved by a symmetrical components.

- (ii) With the aid of diagram describe a symmetrical balanced system and symmetrical unbalanced system

- (b) A phase components of unbalanced condition of a system is shown by the phasor form in figure IV below, if  $V_a = 5\angle 53^\circ$ ,  $V_b = 7\angle -164^\circ$ ,  $V_c = 7\angle 105^\circ$ , find the symmetrical components.

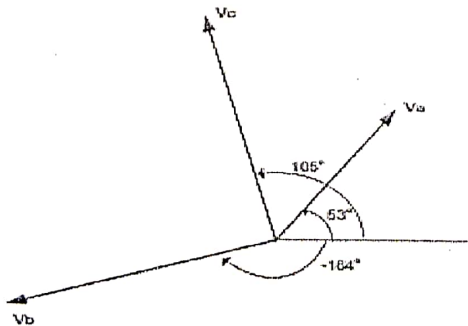

Fig. IV